

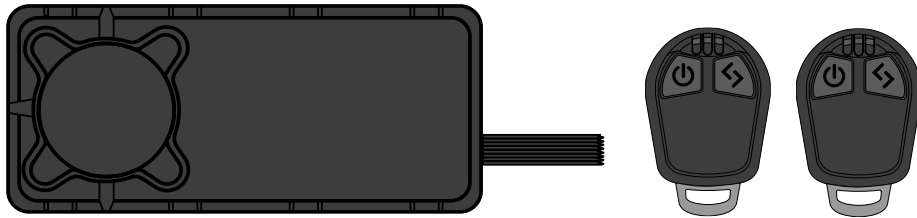

## DT202 Installation Manual

Revision 1 24-07-2023



**IMPORTANT:** This installation manual is produced by Datatool Ltd support to authorised installers of the DT202 series alarm system.

Due to the sensitive nature of its contents, Datatool Ltd specifically forbid its contents to be copied or reproduced and transmitted to any third party without the prior permission in writing of Datatool Ltd.

Any person(s) found to be in breach of this may find themselves removed from the list of Datatool registered installers and subject to prosecution.



**Datatool is a brand of Scorpion Automotive Ltd**

Scorpion House, Drumhead Road, Chorley North Business Park, Chorley, Lancashire, England. PR6 7DE  
Tel: +44 (0) 1257 249928 E mail: [info@datatool.co.uk](mailto:info@datatool.co.uk) Web: <http://www.datatool.co.uk>

# Index

System Overview	Page 1
Specifying the system	Page 2
Thatcham evaluation number and UNECE Regulation No.10 Approval	Page 2
Pre installation checks	Page 3
Stripping the machine	Page 3
Planning the installation	Page 3
Mounting the unit	Page 4
LED mounting methods and position	Page 4
Planning the wiring	Page 5
Connection methods	Page 5
Wiring Connections	Page 5 - 10
Wiring schematic	Page 11
DT202 Operating Guide (Installer Version)	Page 12
The remote control	Page 12
Replacing the battery	Page 12 - 13
Operating the DT202 basic functions	Page 13
Arming the system	Page 14
Disarming the system	Page 14
Passive arming	Page 14
Operating the DT202 Advanced Features	Page 14
Arm/ disarm Silently	Page 14 -15
Automatic rearming	Page 15
Arm in transport mode	Page 15
Long term storage mode	Page 15 - 16
Bike finder	Page 16
Panic alarm	Page 16
Battery monitoring	Page 17
Optional Supplementary Siren Output	Page 17
Optional Secondary Trigger	Page 18
Diagnostics	Page 18
Troubleshooting	Page 19
Customising the system	Page 19
To adjust the arm/disarm tone	Page 19
To adjust the automatic rearm	Page 20
To adjust the passive arming time	Page 20
To choose the motorcycle battery type	Page 21
To reset the DT202 to the default settings	Page 21
To add a new remote control	Page 21 - 22
Inclination Trigger Setting	Page 22
Technical Specification, F.A.Q. and Warranty	Page 23 - 24

## DT202 Series Alarm Overview

The DT202 is an alarm system designed specifically to complement the original equipment immobiliser system on the motorcycle. The DT202 is purely an alarm system, the immobilisation functionality is handled by the motorcycle ignition system.

When armed the DT202 monitors the motorcycle for signs of unauthorised movement by use of a movement sensor, unauthorised ignition operation and unauthorised access to the alarm control unit as well as battery disconnection. If any of these conditions are detected the alarm siren will sound and the motorcycle indicators will flash except if the motorcycle battery has been disconnected, where the siren will still sound using an internal rechargeable battery in the DT202, but the motorcycle indicators will not flash. The siren will operate for 29 seconds, then re-arm. This will be repeated 10 times if the alarm trigger remains. After the activation cycle has been repeated 10 times the siren will no longer sound on that circuit until the next alarm arm/disarm, all other circuits remain active though.

The information contained in this publication is accurate at the time of final approval, however, Datatool reserves the right to amend the information at any time without notice.

### Insurance Approval

The DT202 is accredited in the UK as a Thatcham Category 2:1 upgrade alarm, designed to be installed on all motorcycles equipped as standard with an original fit, or aftermarket Thatcham approved Category 2 immobiliser.

When installed to the correct specification motorcycle, the DT202 upgrades the motorcycle approval to full Thatcham Category 1 status.



### Unit Dimensions

Length:	118mm
Width:	51mm
Height:	26mm

## Specifying the system

There are 2 different models within the DT range, the DT202 (Thatcham Category 1) and the DT202 (Thatcham Category 2-1). Both are Thatcham accredited but for different applications. If the security system is being installed to meet an insurance requirement, it is critical the correct alarm system is chosen. If a unit is installed which is of a lower standard than required, the only solution is to de-install and fit the correct unit. Datatool Ltd cannot be held responsible for incorrect choice of product for any installation.

Many motorcycles are now equipped with 'chip in key' transponder immobilisers as standard however not all of these motorcycles have Thatcham approved immobilisers and therefore may not qualify as an 'insurance approved' product.

When selecting whether a machine should be equipped with an DT202 (alarm/immobiliser) or DT202 (alarm upgrade) this MUST be taken into account. The DT202 product only gives insurance benefits if fitted onto a motorcycle already complying with Thatcham Category 2 immobilisation. The latest list of approved motorcycles and security systems can be downloaded from Thatcham here:

<http://www.thatcham.org/files/pdf/compliance.pdf>

If you are unsure of the unit required, please refer to the Thatcham listing or contact Datatool at [info@datatool.co.uk](mailto:info@datatool.co.uk) for assistance.

The information below sets out the main requirements when selecting the required unit, along with the Thatcham approval number. It is possible to fit a unit of a higher standard than the minimum required without adverse effect on both the operation of the unit and insurance premium.

All Thatcham listed systems must be fitted by an approved Datatool Dealer only. Due to safety issues, Scorpion Automotive Ltd reserve the right to withdraw supply to any dealer found to be supplying Thatcham listed alarm/immobilisers without fitting.

If the customer does not require an insurance approved system the Datatool Evo or Evo Plus maybe installed instead, these units can be sold as supply only for the customer to fit themselves. **The DT series alarms are intended for professional installation only and must not be sold for customer installation.**

### Thatcham Evaluation Numbers

Model	Description	Thatcham Category	Thatcham Approval
DT202	Alarm (All motorcycles installed with a category 2 immobiliser)	Cat 2-1	TSC482

### UNECE Regulation No.10 Approval

Model	Description	VCA Approval No.
DT202	Alarm/Immobiliser (All motorcycles)	E11*10R06/01*10835*01

## Customer Decisions

Due to the design of the DT202 it is possible to configure the system in several ways. It is advisable to discuss the options available with the customer prior to installing the system. Some of the features may not be applicable to certain markets due to local regulations (e.g., arm/disarm tone).

First select the type of security system the customer requires and then discuss any specific requirements the customer may have (e.g., LED position, full passive arming, etc.).

## Pre-installation checks

- Never install an alarm to a machine you have not checked out electrically and heard running.
- Always carry out a full visual inspection of the machine prior to installation, particularly if the machine is second hand or has been brought in for an alarm to be installed. Any faults or damage discovered should be reported to the owner or their agent prior to carrying out the installation of the system.
- The battery for the machine should be checked for full charge prior to installation. If it is found to be low it is advisable to place it on charge. The Datatool Smart Charger battery conditioner will bring the battery up to full charge safely in the minimum time. Should the battery be in a poor state, it is strongly advised the customer is informed the battery needs replacement as the alarm, although only drawing less than 3mA when not charging the internal battery, the alarm will increase the loading on the battery.

## Stripping the machine

- Always take extreme care when removing and storing panels from the machine to ensure they do not get damaged.
- Always note the size, type and position of any fixing you remove. It is very easy to forget what goes where.
- Should a panel prove difficult to remove, take a further look to ensure the strip sequence is correct and that all fixing devices have been removed (it's very easy to miss that little hidden clip).

## Planning the installation

The alarm components should be located to ensure the maximum time is required for the thief to access the system. Other factors such as the storage of customer's personal belongings and other equipment such as intercoms, chain oilers, etc. should also be considered.

Always plan the physical position for all the alarm components prior to installation. If there is any doubt on panel fit, ALWAYS temporarily mount the unit and refit the panel prior to wiring the alarm. Once the alarm has been installed it may be impossible to move the position to a new location. A few moments spent checking at this point can save several hours of re-working

## Cable Tie Mounting Technique

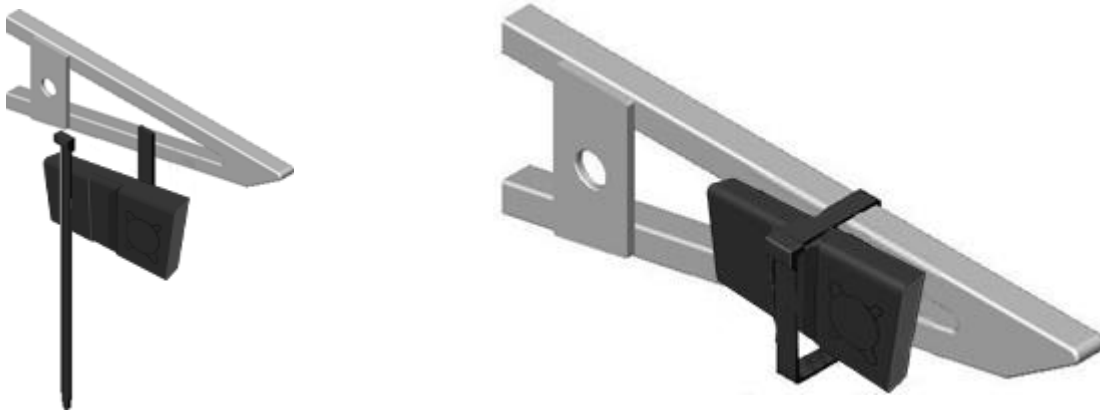

If mounting the alarm unit onto the frame of the motorcycle ensure the foam pad is placed between the alarm and the motorcycle frame.

## LED Mounting Methods & Position

Where possible the position of the system LED should be agreed with the owner prior to installing. The LED is the effectively first line of protection and should be mounted in a highly visible position to ensure maximum deterrent effect. Installation options are shown below:

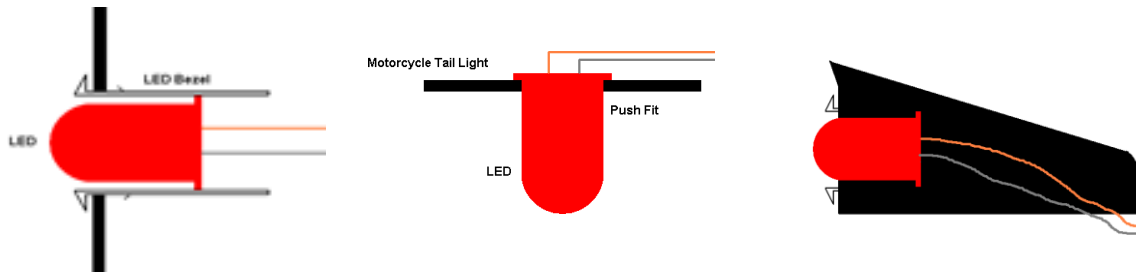

The LED may be mounted through an inner fairing panel, surface mounted using the adapter supplied in the fixing kit or even mounted through a light lens into a tail light unit. Warning: When fitting into an LED tail light take care not to damage LED PCB

Only when the main unit positions have been established, should the wiring be started.

## Planning the Wiring

Access the wiring harness at the most suitable place(s) and identify the wires you are going to connect to using suitable safe test equipment.

Analogue meters and bulb-based test lights are low resistance and can easily damage delicate electronic units fitted to some motorcycles. It is advisable to use high resistance test equipment (e.g. Digital multi-meters, LED based test lights {logic probes}, LCD testers).

If you have doubts regarding the suitability of your test equipment, please refer to the manufacturer's workshop manual.

Once the alarm wiring points have been selected, construct the alarm harness accordingly. When constructing the alarm loom pay close attention to the positioning of the alarm plugs in relation to each other

When routing the alarm harness, it is advisable to run it alongside or within the original wiring harness of the machine and loom/sleeve it in a similar manner to the original harness where possible. The loom must be protected from any sharp edges likely to cause damage to the harness.

## Connection Methods

Soldered joints are recommended for all wiring connections, protected by a suitable insulation technique (adhesive lined heat shrink, self-amalgamating tape and good quality insulation tape, correctly applied).

Where connectors are used, they must be to at least the same standard as the machine's original equipment. Insulation displacement connectors (Scotchlocks) must **NOT** be used under any circumstances.

## Wiring Connections

All DT202 alarm systems are designed to work on 12-volt negative earth electrical systems only. Do not install this product to a positive earth machine.

The main positive and negative connections are the most important wires of any alarm system as they supply the power to make most of the other functions work.

### Main Positive Supply (Red wire)

The red wire is the main power supply to the DT202 alarm and requires a permanently live 12v positive feed.

Many motorcycles are now equipped with a dedicated permanent 12-volt positive feed designed to power an alarm system. Alternatives can be the clock or fan fuse. The rating of this fuse should be between 10 and 20 amps. If the rating is below this the fuse may blow when indicators flash via the alarm system

The alarm is equipped with internal protection to deal with shorts on the indicators but it is always advisable to fit a dedicated protection fuse onto the alarm power supply as this protects the wiring from the fuse to the alarm unit itself. Where possible the fuse should be fitted as close as possible to the source of power. The supply should never be taken directly from the battery.

## Main Negative Supply (Black wires)

The DT202 has 2 earth wires it is very important these two wires are connected to two separate permanent earth points on the machine, never drill the frame to make an earth connection.

These points can be on the frame or within the wiring harness but should never be mixed and never taken directly to the battery. Any harness-based earth should be tested to ensure it is a true earth and does not change when the ignition is turned on and switches are operated. If unsure refer to the motorcycle's wiring diagram.

We advise the use of harness-based earths in most cases. Frame earths, especially on anodised frames, can be very poor.

## The 12 volt Positive Ignition Switched Supply (Brown wire)

This wire stops the alarm from arming when the ignition is turned ON

It is important the wire remains positive when any of the motorcycles controls are operated to prevent arming of the alarm system whilst riding the motorcycle. For this reason, we advise you connect to an ignition switched positive supply which is run critical.

One exception to this is using a kill switched controlled ignition supply. This is acceptable but it must be explained to the customer if the kill switch is turned to off the alarm is able to arm if passive arming is selected or the remote control arm button is pressed.

Many installers use other circuits (e.g., the rear brake light supply). Whilst this will work it should be realised if the fuse blows to this circuit due to a fault on the motorcycle itself, the alarm is able to arm if passive arming is selected or the remote control arm button is pressed.

On some motorcycles certain ignition switched positive circuits turn off whilst the starter button is being operated to reduce the load on the battery. This is particularly true of lighting circuits, therefore it is important to ensure the chosen 12v switched feed stays live when the engine is cranking.

On certain motorcycles with CANBUS electrical systems, there may be a slight delay between the ignition being switched off and the chosen switched feed dropping to zero volts. This is quite normal on this type of machine and simply delays the arming period of the alarm by the time it takes for the ignition control relay of the machine to reset.

## The Indicator Connections (2 x Pink wires)

The DT202 alarm provides visual indication of arm/disarm and alert by providing a 12v positive feed on both pink tagged wires intended to be connected to the indicator circuits. It is important on motorcycles fitted with LED indicators that the voltage at which the indicators operate (i.e. the voltage the machine provides to the indicators) is ascertained before making any connection to the indicator circuits. Some motorcycles are now using 5v LED indicators which will be permanently damaged if connected to the 12v feed provided by the DT202 alarm.

The alarm system should be connected to the left and right indicator positive feeds. Do not connect to the negative wire of the indicator and do not connect to the indicator relay output. On some motorcycles you may only be able to make the rear or front indicators operate without the inclusion of extra diodes into the indicator outputs of the alarm system.



Important note: On certain CANBUS based motorcycles the original indicator lines to the indicators must be cut and an in-line diode fitted into each of the original indicator wires with the banded end of the diode towards the indicator bulb. The pink wire of the alarm must then be connected to the banded side of the diode. Failure to do this will cause the machine to log a fault each time the alarm system is armed as the control unit of the machine will see the pulse coming from the alarm. All 4 indicators can be connected to but a diode must be installed in each indicator wire.

### The Indicator Diode Test

Some motorcycles require an in-line diode to be installed into the wiring of the indicator circuit. To determine if this is required, carry out the following test after installing the alarm.

- With the ignition turned OFF, position the indicator switch of the machine so it would be set to flash the indicators either right or left, it doesn't matter which way.
- Position the light switch of the machine (if fitted) so the lights would be on if the machine was running.
- Arm or disarm the alarm whilst looking at the dash lights and instruments to see if anything other than the indicator repeater lights works. If this happens with the indicator set to left or right; a diode is required.
- Arm or disarm the alarm and check to see if the headlight or side light illuminates.
- Test the starter button to see if the machine cranks (always check the machine is in neutral and any interlock systems on the machine are set to the run position, e.g. kill switch, clutch, side stand, etc.).
- If during these tests any extra lights or instruments operate, the alarm fuse blows or the machine cranks over, a diode will have to be inserted in line with the input or output of the indicator relay.

### Installing a Diode into the Indicator Relay Circuit

The diode can be fitted in either the feed to the relay from the fuse box or the output from the relay to the indicator switch, it doesn't matter which as long as it is connected the correct way round.

The input wire will be an ignition switched positive from the fuse box to the indicator relay. If this wire is cut the band on the diode should face towards the relay

The output wire is the feed to the indicator switch which provides the pulsed output to flash whichever side indicators are selected via the switch. When this wire is cut the diode is positioned with the band facing away from the relay.

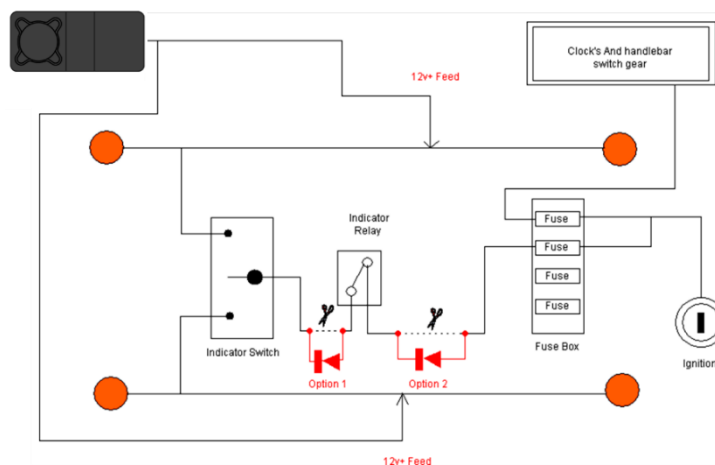

If you are unsure which way to fit the diode, cut the selected wire; hold the diode in line and with the ignition on set the indicator to the left or right. If the indicators work normally, you have got it the right way round. If they do not operate, reverse the diode and test again. Once you have it the right way round, solder it in line and protect the joints with heat shrink or good quality tape

## Alarm Protection Switch (Blue and White wires loomed together)

All Thatcham Cat 1 and Cat 2-1 products must be protected by an Alarm ECU protection switch. The kit comes supplied with a magnetic reed switch for this purpose and **MUST** be installed.

The switching arrangement is normally closed (N/C). The white wire is the trigger line and the blue wire is an earth supplied from the alarm. When armed if the earth is not present or is removed during the armed period from the white wire the alarm will trigger.

Fit the magnetic reed switch so the alarm would be triggered by the removal of a seat or body panel before the alarm ECU is accessed.

Choose an area where the switch and magnet can be placed in close proximity to each other. When correctly oriented the air gap can be **up to** 35 mm, however mounting the switch or magnet on ferrous metal (steel) or rotating the magnet will reduce this range. Do not mount the switch/magnet assembly with steel in between.

Connect the two wires of the switch, one to the white wire of the alarm and the other to the blue wire of the alarm. The switch has a self-adhesive backing to assist in mounting and is also supplied with screws if this method is preferred. If using the self-adhesive system, clean and de-grease the area thoroughly prior to fitting. Fit the magnet on the removable panel/seat adjacent to the switch using the fitting methods described above.

When correctly set; the switch should activate the alarm before the panel is removed by 50mm. The position of the switch/magnet should be adjusted accordingly to achieve maximum protection but to avoid false alerts.

If more than one area is to be protected, extra magnets and switches are available through Datatool, this is a chargeable extra. Extra magnets may also be needed if the pillion seat is used and the customer has a separate tailpiece. If several switches are to be used they must be run in series, not parallel. This method also applies to accessory loop protection where in-line connectors are positioned so soft luggage/accessories can be protected by running an extension wire through them and remaking the continuous trigger circuit.

## The System LED Connections (Orange and Grey wires)

The system LED provides the first line of defence as a visual deterrent and provides information regarding the status of the alarm system. Where possible agree the position for the system LED with the customer when discussing their requirements and fit it accordingly.

Do not fit more than one LED, it will increase the current usage of the system. The LED can be installed by three methods:

- In its plastic shroud via a drilled 8mm hole
- By use of the self-adhesive LED holder provided in the fixing kit in conjunction with the plastic shroud.
- By an interference fit of the LED into an exact size hole drilled for the LED only (hole size 5mm)

A popular solution is to install the LED into the rear tail light or indicator for greater visual impact. With the current trend towards LED based rear light clusters it is very important the circuit board on the tail light is not damaged. It is unadvisable to drill the back of the tail light of this design unless you are absolutely sure you will not damage the LED array. Often on this type of display it is possible to carefully drill the assembly so the alarm LED is fitted between the LED array and the lens of the tail light (normally at the top). When doing this, the LED wires themselves normally have to be bent over. Always position the LED so the wires can be bent in the right direction easily. Take care not to bend the LED wires over one another.

Consider if the LED needs to be disconnected to service or clean the machine. If it does it may be better to install bullet connectors to make the process easier.

Should you decide to use bullet connectors, always fit a female bullet on the grey tagged wire coming from the alarm and a male bullet on the orange tagged wire. The grey tagged wire carries the LED positive supply so by fitting the female bullet to it you protect it from shorting out. It also means should you ever need to replace or refit the LED you will always connect it the right way round.

Connect the grey wire to the grey wire of the LED, and connect the orange wire to the orange wire of the LED.

**IMPORTANT:** The system LED is rated at 2 volts **DO NOT TEST IT ACROSS A 12 VOLT BATTERY - IT MAY EXPLODE!** If you wish to test the LED directly use a 1.5v battery, the grey wire of the LED is positive the orange wire is negative

## Secondary Trigger (Green Wire)

The use of this wire is not mandatory when fitting a Thatcham alarm system so this option should be discussed with the customer prior to installation.

The secondary trigger input operates on a change of state principle, open circuit then earthed to trigger or resting at earth the open circuit to trigger. During the arming up period the secondary trigger state is recorded, and then when fully armed if the second trigger state changes then the alarm will trigger.

Possible uses include:

- Accessory Loop – to protect luggage / easily removed accessories (diagram below)
- Side stand trigger - activates the alarm if the side stand is retracted (diagram below)
- Clutch Switch trigger - activates the alarm if the clutch lever is pulled in (see Side Stand trigger diagram)
- Secondary panel/luggage protection (fitted as the alarm protection switch above)

Please note the following when determining the options:

- It is not possible to combine an 'earth to trigger' circuit with a 'remove an earth to trigger' on this single wire.
- If a closed loop system is being used all switches must be in series.
- If multiple applied earth triggers are being used they should be wired in parallel and are best separated by diodes. This is particularly important if any machine interlock systems such as side stand switch or clutch switch are to be incorporated. Failure to diode these interlocks away from other triggers may seriously effect safety.

If you do not use this wire it should be positioned in a safe and its position noted, so it can be identified and accessed at a future date.

**Accessory Loop**

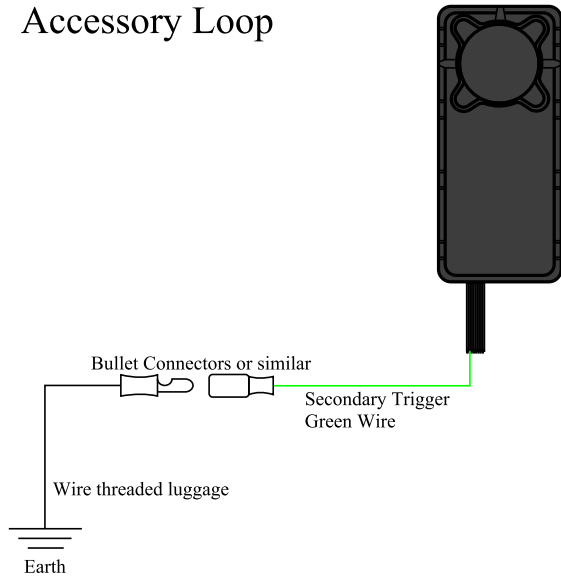

**Side Stand Trigger**

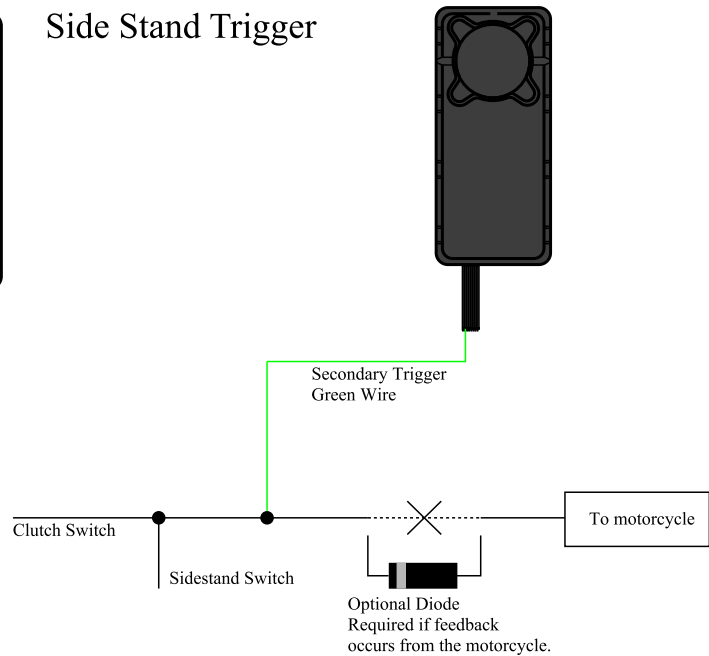

**The Optional Supplementary Siren Output (Yellow Wire)**

The wire with gives a maximum 500mA of negative output only when the siren is sounding. This can be used to drive an additional siren, paging/text system or to activate a tracking system. Any such items are not part of the standard installation and therefore should be treated as extras and charged accordingly.

Some devices require a negative signal to trigger them, in these cases the signal can be converted via a standard automotive 12 volt switching relay. If more than 500mA is required to drive the supplementary device(s); use the output to drive a relay.

If you are not using this output the end of the wire should be insulated, and stored safely in a suitable position and its position noted, so it can be identified and accessed at a future date.

# Wiring Schematic

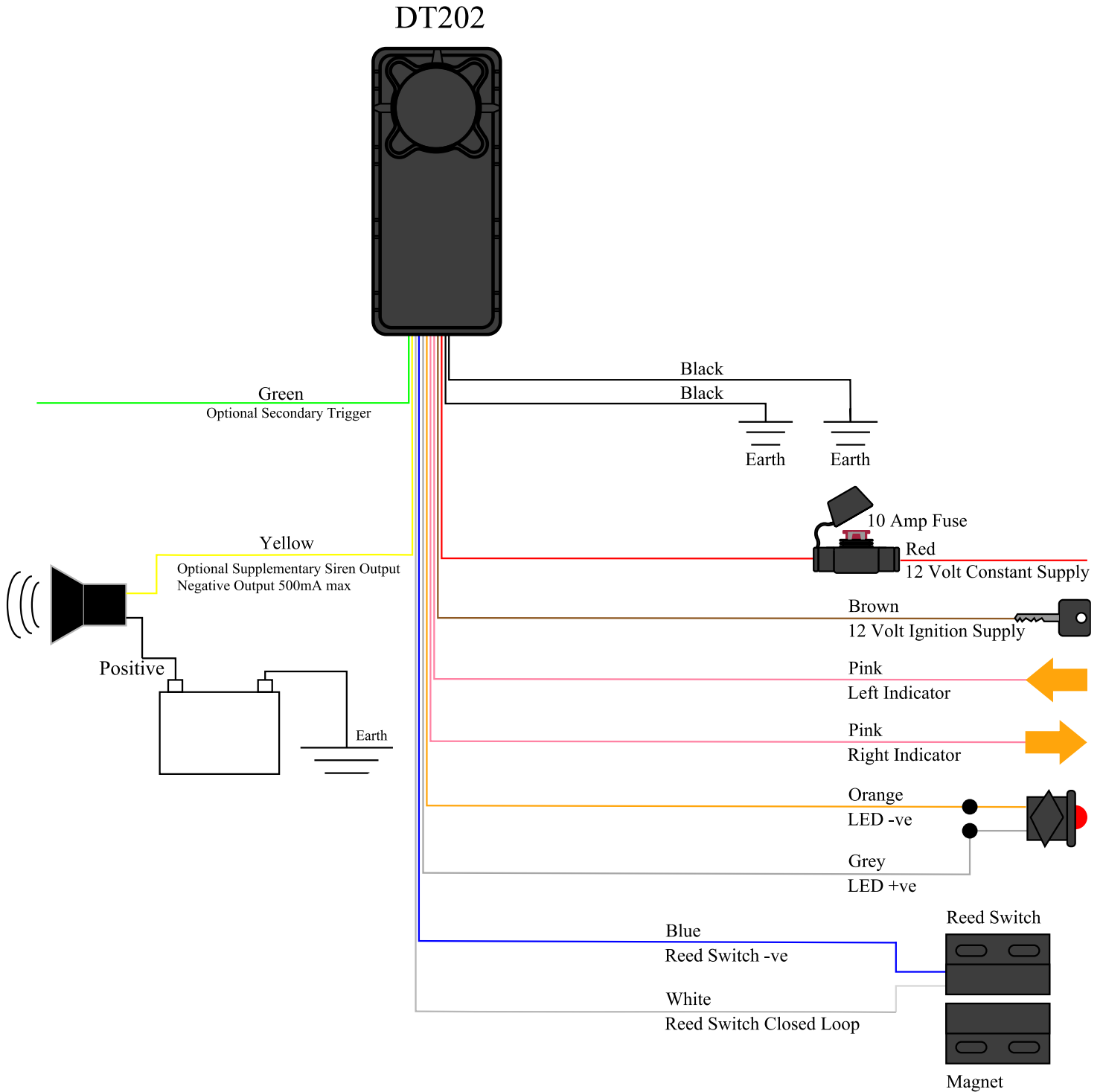

## Operating Instructions

### The Remote Control

The DT202 is provided with 2 remote controls as standard. It is possible to add up to 4 extra remote controls (6 in total). We recommend making use of both remote controls from time to time, ideally alternating use every 3 to 6 months.

The left hand 'Arm/Disarm' button controls the main arm/disarm functions of the system.

The right hand 'Programming' button is used to initiate secondary functions such as movement sensor deactivation (Transport Mode) and bike finder.

When either button is pressed on the remote control, the LED indicator will illuminate to confirm the button has been pressed and the remote transmitter is operating. If the LED indicator does not illuminate when either button is pressed replace the battery as detailed below.

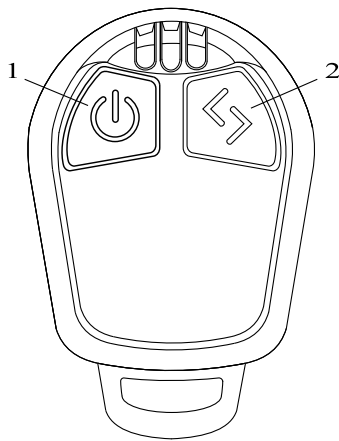

1. **Arm/Disarm button**
2. **Programming button**

### Replacing the Battery

Each remote control contains a single long-life lithium battery (CR2450). Please replace the remote battery when the range of operation decreases noticeably.

**NOTE:** Ensure the used battery is disposed of, or recycled in accordance with local environmental regulations. Incorrect disposal or recycling of a battery may result in prosecution.

1. To replace the battery, locate the recess in the edge of the remote control casing and gently prise the upper and lower sections of the casing apart at this point.

#### CAUTION

When removing, or fitting a battery in the remote control ensure it is removed or fitted in the correct direction. Failure to remove or fit a battery correctly could result in damage to the remote control and possible malfunction.

- The battery is retained by a clip on the remote control circuit board and can be removed by sliding the battery out from under the clip in the direction shown. Fit the new battery, ensuring the battery polarity is correct, by sliding the battery under the retaining clip in the direction shown.

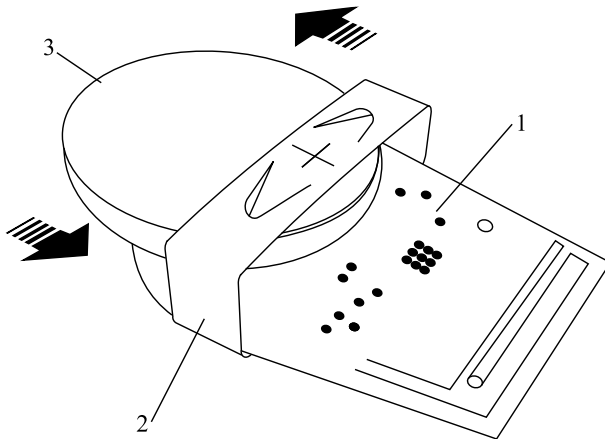

- Remote control circuit board
- Retaining clip
- Battery

- Align the two casing halves and squeeze firmly to click the casing back together, ensuring the joint is even around the perimeter.

## Operating the DT202 Basic Functions

Arming (turning the DT202 on) and disarming (turning the DT202 off) are the most common interactions and can be performed with a single button operation on the remote control.

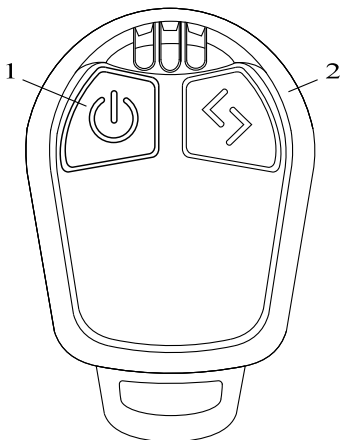

- Arm/Disarm button
- Programming button

## Arming the DT202

To manually arm the DT202 with the motorcycle ignition switched off press the Arm/ Disarm button on the remote control once. The indicators will flash twice and if arm/disarm tones are enabled, a double chirp will be heard.

The dedicated alarm LED in the motorcycle instruments will illuminate for 3 seconds and then flash once every second for a further 10 seconds whilst the system initializes the tilt sensor and trigger inputs. After 10 seconds, the DT202 is fully armed, and the motorcycle LED will flash at a rate determined by the motorcycle battery voltage (see Battery Monitoring).

## Disarming the Alarm

To disarm the DT202 press the Arm/ Disarm button once. The indicators on your motorcycle will flash once to confirm the DT202 has disarmed and if the audible chirps are enabled, a single chirp will be heard, if the alarm system has triggered during the armed state then the siren will sound a chirp followed by a diagnostics sequence (see Diagnostics). The motorcycle ignition can now be turned on without triggering the DT202. The DT202 cannot be re-armed within 3 seconds of disarming. On disarming of the alarm system, if Automatic Rearming is enabled the alarm LED will remain solid to indicate this will occur.

## Passive Arming

With Passive Arming enabled there is no need to press the Arm/Disarm button to arm the DT202. Once the motorcycle ignition is switched off the DT202 the alarm LED will illuminate solid to indicate Passive Arming is enabled and the alarm system will fully arm after the chosen delay period, which can be chosen by the user from 30 seconds or 1 minute. The indicators will flash twice and if arm/disarm tones are enabled, a double chirp will be heard automatically arming.

If the Alarm Protection Switch is activated and remains activated once the alarm system arms the directional indicators and the siren will sound at full volume.

Passive Arming is disabled by default.

## Operating the DT202 Advanced Features

In addition to the basic functions the DT202 also offers the following advanced features:

- Arm silently (if tones enabled)
- Disarm silently (if tones enabled)
- Arm in Transport Mode
- Long Term Storage Mode
- Bike Finder
- Panic Alarm
- Battery Monitoring

## Arm Silently

If the arm/disarm tones are enabled, it is possible to arm the DT202 silently by pressing the Programming Button on the remote immediately before pressing the Arm/Disarm button.

The buttons must be pressed within 3 seconds of each other, the DT202 will arm as normal except the arming notification tones will not be sounded. Subsequent arming sequences will not be affected.



## Disarm Silently

If the arm/disarm tones are enabled, it is possible to disarm the DT202 silently by pressing the Programming Button on the remote immediately before pressing the Arm/Disarm button.

The buttons must be pressed within 3 seconds of each other, the DT202 will disarm as normal except the disarming notification tones will not be sounded. Subsequent disarming sequences will not be affected. On disarming of the alarm system, if Automatic Rearming is enabled the alarm LED will remain solid to indicate the this will occur.

## Automatic Rearming

When enabled, the Automatic Rearming feature will arm the DT202 if the DT202 has been disarmed via the two-button remote and the ignition is not switched on within 30 seconds. On disarming of the alarm system, the alarm LED will remain solid to indicate the alarm system Automatic Rearm will occur.

Turning on the ignition or arming via the two - button remote will cancel the Automatic Rearming feature. Automatic Rearming is disabled by default.

To ensure the machine remains covered at the level chosen if it is accidentally disarmed, when the system is disarmed it automatically starts a 30 second countdown after which the system will auto re-arm at the SAME level it was last armed; be it fully armed, armed in Transport Mode or immobiliser only.

**NOTE:** The DT202 will not automatically arm as a result of the ignition being switched off, unless Passive Arming is enabled. However Passive Immobilisation will occur after 30 seconds.

## Arm in Transport Mode

To arm the DT202 in Transport Mode, first press the Arm/Disarm button as normal to arm the DT202. Then, within 3 seconds of the first button press, press the Programming button which will disable the movement sensor; the DT202 will chirp a third time (if tones are enabled) and the indicators will also flash a third time to indicate the movement sensor has been disabled.

The motorcycle instrument LED will now double flash instead of single flash to identify Transport Mode has been activated.

Transport Mode allows the bike to be moved around (for example when cleaning) or transported in a van without the DT202 triggering due to movement.

**NOTE:** Ignition detection and ECU protection switch detection remain fully active.

To exit Transport Mode simply disarm the DT202 using the Arm/Disarm button and rearm the DT202 if required.

## Long Term Storage Mode

Long Term Storage Mode, also known as 'Winter Mode' is used for motorcycles that are not ridden for long periods and which are stored securely. When in this mode the DT202 draws negligible current and will only respond to the ignition being switched on, the movement sensing and ECU protection switch detection are inoperative.

To enter Long Term Storage Mode, disarm the DT202 and with ignition off hold down both buttons on the two-button remote for 10 seconds. A loud bleep will be heard, and the DT202 system will now be inactive.

To exit Long Term Storage Mode, turn the motorcycle ignition on the motorcycle indicators will start to flash and the DT202 will sound a series of fast beeps that rise in volume. Press the Arm/Disarm button to disarm the DT202. If the Arm/Disarm button is not pressed the DT202 will trigger fully and the siren will sound.

**NOTE:** Long Term Storage Mode should also be used to prevent the DT202 from triggering if the

motorcycle battery needs to be disconnected for any reason.

 **CAUTION**

**CAUTION:** The customer's insurance company may not include cover for an alarm in Long Term Storage Mode.

The level of security is reduced when the DT202 is in Long Term Storage Mode.

The customer should always check the details of your insurance cover before using the Long Term Storage Mode.

 **CAUTION**

**CAUTION:** Prolonged storage of the motorcycle with the DT202 armed will result in battery drain.

Excessive battery drain will cause permanent damage to the battery.

The motorcycle should be connected to an appropriate battery conditioner to maintain good battery condition.

## Bike Finder

The Bike Finder feature flashes the directional indicators so that the rider can identify the location of their motorcycle from afar without disarming the DT202.

Bike Finder is only operational when the DT202 is fully armed and can be activated by pressing the Programming button on the remote control for 3 seconds. The motorcycle indicators will flash 10 times then stop.

Pressing the Programming button during the directional indicator flashes will cause the flashing to stop (Note: No need to press and hold).

The DT202 cannot be disarmed whilst the Bike finder Function is operational, triggering the alarm, during the bike finder flashes will stop the flashes.

## Panic Alarm

**NOTE:** The Panic Alarm does not operate with the ignition ON.

The DT202 offers a 'Panic Alarm' facility that will cause the DT202 siren to sound and the motorcycle indicators to flash to attract attention. To activate the Panic Alarm, hold down the Arm/Disarm button on the remote control for 3 seconds with the motorcycle ignition turned off.

To cease the Panic Alarm, press the Arm/Disarm button on the remote. The Panic Alarm will run for approximately 5 minutes unless stopped by the remote control.

If the DT202 is disarmed with ignition off, then pressing and holding the Arm/Disarm button for 3 seconds will first arm the DT202 before triggering the Panic Alarm.

If the DT202 is in the armed state, then pressing and holding the Arm/Disarm button for 3 seconds will disarm the DT202 before triggering the Panic Alarm feature. If the Arm/Disarm button is pressed a second time to stop the Panic feature the alarm will always reset to the disarmed state regardless of the previous state. If the Panic alarm is allowed to complete the 5-minute duration then the alarm system will finish in the armed state.

## Battery Monitoring

The DT202 monitors the motorcycle battery voltage and, when the DT202 is armed, flashes the motorcycle instrument LED at a variable rate to notify the measured battery voltage. The LED

flash rate is as follows:

### Lead Acid Battery

Measured Voltage <sup>1</sup>	LED Sequence <sup>2</sup>	Indicative Status
Greater or equal to 11.5 V	Once every 5 seconds	Fully charged battery
Between 11.5V and 10.5 V	Once every 10 seconds	Partially discharged battery
Less than or equal to 10.5 V	Once every 20 seconds	Low battery

1. Voltages are approximate
2. If the movement sensor is disabled, either by use of Transport Mode or via programming then the status LED will flash twice in quick succession to indicate that the movement sensor has been disabled, if the movement has been permanently disabled via programming the indicators flash three times on arming and if arm/disarm tones are enabled, three chirps will be heard.

### Lithium Battery

Measured Voltage <sup>1</sup>	LED Sequence <sup>2</sup>	Indicative Status
Greater or equal to 13.2 V	Once every 5 seconds	Fully charged battery
Between 13.2V and 12.4 V	Once every 10 seconds	Partially discharged battery
Less than or equal to 12.4 V	Once every 20 seconds	Low battery

1. Voltages are approximate
2. If the movement sensor is disabled, either by use of Transport Mode or via programming then the status LED will flash twice in quick succession to indicate that the movement sensor has been disabled, if the movement has been permanently disabled via programming the indicators flash three times on arming and if arm/disarm tones are enabled, three chirps will be heard.

## Optional Supplementary Siren Output

The DT202 allows for the addition of an optional second siren using the Optional Supplementary Siren Output, if used with a suitable siren this can increase the output volume when the alarm is sounding.

Alternatively, the output can be connected to a pager input, allowing a notification to be received on your pager device in the event of an alarm trigger occurring.

**If you would like to use the Optional Supplementary Siren output feature speak to your installing dealer.**

## Optional Secondary Trigger

The Optional Secondary Trigger allows the motorcycle or its accessories to be protected in the following ways listed below, it may only be possible to use one of the methods listed below at a time and some options may not be available on certain models of motorcycle.

- Closed Loop – This allows a loop of wire to pass around an accessory or luggage attached to the motorcycle. Should the cable be cut to remove the accessory or

**Datatool is a brand of Scorpion Automotive Ltd**

Scorpion House, Drumhead Road, Chorley North Business Park, Chorley, Lancashire, England. PR6 7DE  
 Tel: +44 (0) 1257 249928 E mail: [info@datatool.co.uk](mailto:info@datatool.co.uk) Web: <http://www.datatool.co.uk>

luggage with the alarm in an armed condition the alarm will trigger.

Please note the cable should be fully in place and the connected before arming the alarm.

- Additional Locker Protection – Additional magnetic reed switches can be added to protect a seat, panel or storage compartment, if installed an alarm trigger will occur if a seat, panel or storage compartment be open or removed that has a switch installed.

Please note all protected seat, panel and storage compartments should be fully in position or closed before arming the alarm system.

- Side Stand – If connected the alarm will monitor the state of the side stand when armed, if the position of the side stand is changed during the armed period of the alarm system the alarm will trigger.

Please note it is recommended that if using the side stand as a secondary trigger the motorcycle is left on side stand and not the main stand for maximum protection.

**If you would like to use the Optional Secondary Trigger speak to your installing dealer.**

## Diagnostics

When the DT202 is disarmed via a remote control, a long chirp is given followed by a series of short chirps signifying the DT202 has been triggered.

The diagnostic code can be repeated by switching the ignition on and off, unless the alarm has been rearmed or the ignition has been switched on for 60 seconds or more at which point the code will be erased.

The explanation for the Bleeps is as follows;

Flash Count	Circuit Triggered
One	Ignition
Two	Seat Switch
Three	Secondary Trigger Input
Four	Tilt Sensor
Five	Panic Feature
Six	Power Removal
Seven	Accelerometer Failure
Eight	Software Error

## Troubleshooting

If the DT202 does not react to the remote control when arming or disarming check the following:

- LED Indicator is illuminating on the remote when the Arm/Disarm button is pressed. If not replace the remote control battery.
- Operate the remote directly adjacent to the motorcycle in case of local radio frequency (RF) interference.
- If a local source of RF interference is identified, move the motorcycle away from the area and attempt to operate the DT202 again.

### CAUTION

- It is important that the internal battery in the DT202 is not left in a discharged condition.
- If the DT202 internal battery is left discharged it will result in damage to the battery.
- If the motorcycle is to be left unused for any period beyond two weeks it should be connected to an appropriate battery conditioner to maintain good battery condition.
- Battery issues resulting from improper maintenance are not covered under warranty.

## Customising the System

The DT202 has been designed to be simple to operate and to allow certain features to be programmed to suit personal preference or requirements. The user programmable options are:

- Arm/Disarm tones – quiet, loud or off (default)
- Automatic Rearming - on or off (default)
- Passive Arming at ignition off – activate at 30 seconds, 60 seconds or off (default)
- Battery type – lead acid (default) or lithium ion

**NOTE:** Sensitivity movement can only be adjusted by a dealer.

## Programming Guide

To customise the DT202 features to the user preferred options follow the programming guides below.

### To adjust the arm/disarm tone

1. Disarm the DT202.
2. Turn on the ignition.
3. Within 10 seconds, press and **hold** both buttons on the remote control.
4. After 3 seconds the DT202 will start to chirp loudly. Release the remote control buttons after the first chirp, if you miss the correct chirp wait for the alarm to exit programming mode after the seventh chirp or turn off the ignition a loud chirp will be given to indicate programming has been exited.
5. Once programming mode is entered the DT202 will beep a specified number of times to indicate the current setting, the LED will flash the current setting repeatedly.

6. Press the Arm/Disarm or Programming button on the remote control to cycle through the tone options:
  - **Off** (1 Bleep) (Default)
  - **Quiet** (2 Bleeps).
  - **Loud** (3 Bleeps).
7. Turn off the ignition to exit programming and save the new setting a loud chirp will be given. If the ignition is not switched off within 30 seconds the DT202 will give a loud chirp and the currently selected setting will be stored.

#### To adjust the Automatic Rearm

1. Disarm the DT202.
2. Turn on the ignition.
3. Within 10 seconds, press and **hold** both buttons on the remote control.
4. After 3 seconds the DT202 will start to chirp loudly. Release the remote control buttons after two chirps, if you miss the correct chirp wait for the alarm to exit programming mode after the seventh chirp or turn off the ignition a loud chirp will be given to indicate programming has been exited.
5. The DT202 will bleep a specified number of times to indicate the current setting, the LED will flash the current setting repeatedly.
6. Press the Arm/Disarm or Programming button on the remote control to cycle through the automatic rearm options:
  - **Off** (1 Bleep) (Default).
  - **On** (2 Bleeps).
7. Turn off the ignition to exit programming and save the new setting a loud chirp will be given. If the ignition is not switched off within 30 seconds the DT202 will give a loud chirp and the currently selected setting will be stored.

#### To adjust the Passive Arming time

1. Disarm the DT202.
2. Turn on the ignition.
3. Within 10 seconds, press and **hold** both buttons on the remote control.
4. After 3 seconds the DT202 will start to chirp. Release the remote control buttons after three chirps, if you miss the correct chirp wait for the alarm to exit programming mode after the seventh chirp or turn off the ignition a loud chirp will be given to indicate programming has been exited.
5. The DT202 will bleep a specified number of times to indicate the current setting, the LED will flash the current setting repeatedly.
6. Press the Arm/Disarm button on the remote control to cycle through the automatic arming options:
  - **Off** (1 Bleep) (Default)
  - **30 second delay** (2 Bleeps)
  - **60 second delay** (3 Bleeps)
7. Turn off the ignition to exit programming and save the new setting a loud chirp will be given. If the ignition is not switched off within 30 seconds the DT202 will give a loud chirp and the currently selected setting will be stored.

**To choose the motorcycle battery type**

1. Disarm the DT202.
2. Turn on the ignition.
3. Within 10 seconds, press and **hold** both buttons on the remote control.
4. After 3 seconds the DT202 will start to chirp loudly. Release the remote control buttons after four chirps, if you miss the correct chirp wait for the alarm to exit programming mode after the seventh chirp or turn off the ignition a loud chirp will be given to indicate programming has been exited.
5. The DT202 will bleep a specified number of times to indicate the current setting, the LED will flash the current setting repeatedly.
6. Press the Arm/Disarm or Programming button on the remote control to cycle through the motorcycle battery options:
  - **Lead Acid** (1 Bleep) (Default).
  - **Lithium** (2 Bleeps).
7. Turn off the ignition to exit programming and save the new setting a loud chirp will be given. If the ignition is not switched off within 30 seconds the DT202 will give a loud chirp and the currently selected setting will be stored.

**To reset the DT202 to the default settings (This will not reset the Inclination Sensor)**

1. Disarm the DT202.
2. Turn on the ignition.
3. Within 10 seconds, press and **hold** both buttons on the remote control.
4. After 3 seconds the DT202 will start to chirp loudly. Release the remote control buttons after five chirps, if you miss the correct chirp wait for the alarm to exit programming mode after the seventh chirp or turn off the ignition a loud chirp will be given to indicate programming has been exited.
5. The DT202 will bleep once and the LED repeatedly once every three seconds.
6. Press the Arm/Disarm button on the remote control once, the DT202 will bleep twice and the LED will double flash repeatedly.
7. Press both buttons on the remote control to save the default settings a loud chirp will be given and the alarm will exit programming.

**To add a new remote control**

1. Disarm the DT202.
2. Turn on the ignition.
3. Within 10 seconds, press and **hold** both buttons on the remote control.
4. After 3 seconds the DT202 will start to chirp. Release the remote control buttons after six chirps, if you miss the correct chirp wait for the alarm to exit programming mode after the seventh chirp or turn off the ignition a loud chirp will be given to indicate programming has been exited.
5. The DT202 will give a single bleep and flash the repeatedly once every three seconds.
6. Press either button on the current remote control two bleeps will be given and the LED will double flash repeatedly.
7. Press both buttons together on the remote control, the DT202 will bleep twice and the LED will extinguish.



8. Press either button on the first remote control to be added, the DT202 will bleep once and the LED will flash once indicating the number of remote controls programmed.

**NOTE:** After programming the first remote control all other remote controls will be deleted.

9. Press either button on the following remote controls to be added, the DT202 will bleep once and the LED will flash an extra flash each time a remote control is programmed indicating the number of remote controls programmed.
10. Turn off the ignition to exit programming and save the new settings.

### To choose the inclination trigger setting

1. Disarm the DT202.
2. Turn on the ignition.
3. Within 10 seconds, press and **hold** both buttons on the remote control.
4. After 3 seconds the DT202 will start to chirp loudly. Release the remote control buttons after seven chirps, if you miss the correct chirp wait for the alarm to exit programming mode after the seventh chirp or turn off the ignition a loud chirp will be given to indicate programming has been exited.
5. The DT202 will bleep a specified number of times to indicate the current setting, the LED will flash the current setting repeatedly.
6. To enable editing of the inclination settings by a dealer press the two-button remote control in the following combination: (Arm/Disarm Button), (Function Button), (Function Button), (Arm/Disarm Button). The gap between button presses should be no more than 3 seconds. The alarm system will respond by signalling the current setting using chirps.
7. Press the Arm/Disarm or Programming button on the remote control to cycle through the motorcyclebattery options:
  - **Off** (1 Bleep)
  - **Low Sensitivity** (2 Bleeps)
  - **Medium Sensitivity** (3 Bleeps) (Default).
  - **High Sensitivity** (4 Bleeps)
8. Press both buttons on the remote control to save the default settings a loud chirp will be given, and the alarm will exit programming.



## Technical Specification

RF Device:	433MHz, <1mW ERP
Supply voltage range	9VDC to 16VDC
Supply current disarmed, no internal battery charge	3.1±0.2mA
Maximum supply current disarmed or armed charging internal battery	26mA±0.5mA
Average supply current fully armed	2.9mA±0.1mA
Maximum supply current [long term storage mode]	0.02mA
Maximum directional indicator power per channel	2 x 10W

## List of Batteries Contained Within the Equipment

ECU: Varta, NiMH, 6 button cells, 7.2V nominal. (Rechargeable)

Remote Control: Long life lithium, CR2450, 3V (None Rechargeable)



**Battery Disposal Instructions:**  
 Battery should not be disposed of with general household waste. Bring damaged or worn out batteries to your local recycling centre or dispose of them in battery recycle bins that can be found in store.



Keep batteries out of the reach of children.

## F.A.Q.

### **Which battery does the remote control use?**

The replacement battery for the remote control is the CR2450 and is a long life lithium battery

### **Alarm does not respond when the remote control is pressed.**

Check the LED light on the remote control illuminates when the button is pressed. if the LED light does not illuminate or looks dim change the battery on the remote control, the battery is a long life lithium battery part number CR2450.

**Note: For the alarm system to function correctly it is imperative that the motorcycle battery is fully charged.**

### **Alarm triggers randomly LED diagnostic feedback displays four flashes indicating inclination sensor.**

If the motorcycle is being transported the inclination sensor must be disabled using 'Transport Mode' to prevent false triggering of the alarm. If the motorcycle is not being transported and false triggering occurs the inclination sensor sensitivity may be set to high, the installing dealer will be able to adjust the sensitivity.

### **Alarm triggers LED diagnostic feedback displays two flashes indicating ECU protection switch.**

The ECU protection switch is mounted onto the seat or a panel that must be removed before it would be possible to access the alarm unit, the switch consists of two parts the reed switch and the magnet. The magnet must be close to the reed switch whenever the alarm is armed, once separated the alarm will trigger.

Ensure both the reed switch and magnet are installed and have not been damaged or the position altered from that of the original installation. Contact the installing dealer if this does not remedy the issue.

## Warranty

Datatool DT202 is provided with a comprehensive 2-year warranty in addition to your statutory rights, designed to combat any material or manufacturing defects which become apparent within 2 calendar years from the date of first installation. In the unlikely event of repairs being required under the provided warranty, please contact the installing dealer for assistance.



The full text of the UK Declaration of Conformity and EC Declaration of Conformity is available on the Scorpion Automotive website which can be accessed through the following links:

UK Declaration of Conformity - <https://www.scorpionauto.com/uk-scorpion-automotive-doc/>

EC Declaration of Conformity - <https://www.scorpionauto.com/ec-scorpion-automotive-doc-2/>

**Datatool is a brand of Scorpion Automotive Ltd**

Scorpion House, Drumhead Road, Chorley North Business Park, Chorley, Lancashire, England. PR6 7DE  
Tel: +44 (0) 1257 249928 E mail: [info@datatool.co.uk](mailto:info@datatool.co.uk) Web: <http://www.datatool.co.uk>